

INSTALLATION INSTRUCTIONS AND PARTS LIST

APPLICATION:

MODEL 409921 STEP BRACKETS:

1999 AND NEWER FORD SUPER DUTY REGULAR CAB PICKUPS



1. READ INSTRUCTIONS COMPLETELY AND CHECK TO MAKE SURE THAT ALL REQUIRED PARTS (LISTED ON THE SERVICE PARTS LIST) ARE ON HAND BEFORE STARTING THE INSTALLATION.
2. INSTALL 5/16" MULTI THREAD U-NUTS (ITEM #8) IN THE TOP REAR HOLE OF THE FIRST, SECOND AND THIRD PATTERNS AND IN THE FRONT TOP HOLE OF THE FIFTH OR REAR PATTERN AS SHOWN. INSTALL THESE U-NUTS SO THAT THE THREADS ARE TO THE INSIDE OF THE ROCKER PANEL. (THIS IS DONE BY INSERTING THE THREADED HALF OF THE U-NUT THRU THE LARGE ACCESS HOLES AND SLIDING THE U-NUT TOWARDS THE ROUND HOLE UNTIL IT SEATS IN THE ROUND HOLE).
3. ATTACH THE MOUNTING BRACKETS TO THE VEHICLE AS FOLLOWS: [SEE FIG. 1]
(NOTE: THE FRONT MOUNTING BRACKET, ITEM #1, HAS A 3/16" OFFSET AT THE TOP OF THE BRACKET).
 - 3.1. POSITION THE BRACKETS (ITEM #1,2) ON THE VEHICLE SO THAT THE TOP HOLE LINES UP WITH THE MULTI THREAD U-NUT AND THE BOTTOM HOLE LINES UP WITH THE HOLE IN THE PINCH WELD. ATTACH THE TOP OF THE BRACKET WITH A 5/16" X 1.00" ZINC PLATED HEX HEAD CAP SCREW (ITEM #6) AND 5/16" ZINC PLATED FLAT WASHER (ITEM #7). ATTACH THE BOTTOM OF THE BRACKET TO THE PINCH WELD WITH A 5/16" X 1.00" BLACK PLATED HEX HEAD CAP SCREW (ITEM #3), 5/16" BLACK PLATED FLAT WASHER (ITEM #4) AND 5/16" SERRATED FLANGE NUT (ITEM #5). LEVEL THE BRACKETS AND TIGHTEN THE BOLTS.
4. ATTACHING THE STEP ASSEMBLY:
PLEASE REVIEW THE INSTALLATION INSTRUCTIONS THAT ARE INCLUDED IN YOUR STEP ASSEMBLY FOR SPECIFIC DETAILS.

SERVICE PARTS LIST

ITEM	PART NO.	QTY	DESCRIPTION
PARTS INCLUDED IN THE BRACKET PACKAGE			
1	551855	2	BRKT- MTG, STEP, SUPER DUTY PICKUP, FRONT
2	551854	4	BRKT- MTG, STEP, SUPER DUTY PICKUP
3	106997	6	SCREW- HEX HEAD CAP, 5/16-18 UNC X 1.00", SST, BZP
4	106998	6	WSHR-PL, A, SST, 5/16,.375 ID X .875 OD X .083 THK, BZP
5	102680	6	NUT-SERRATED FLANGE, HEX, SST, 5/16-18 UNC
6	100647	6	SCREW- HEX HEAD CAP, 5/16-18 UNC X 1.00".ZP
7	100034	6	WSHR-PL, A, STL, 5/16,.375 ID X .875 OD X .083 THK, ZP
8	104264	6	U-NUT- MULTI THREAD, 5/16-18 UNC, STL, BLK

LIVERNE
TRUCK EQUIPMENT

(A LIVERNE Company)

1200 E. Birch St.

Brandon, SD 57005

REVISION B 05MAR12
REVISION A 11OCT11
551963 SHEET 1 OF 2 28JUL11

SERVICE PARTS LIST

BRACKET NO. - 409921

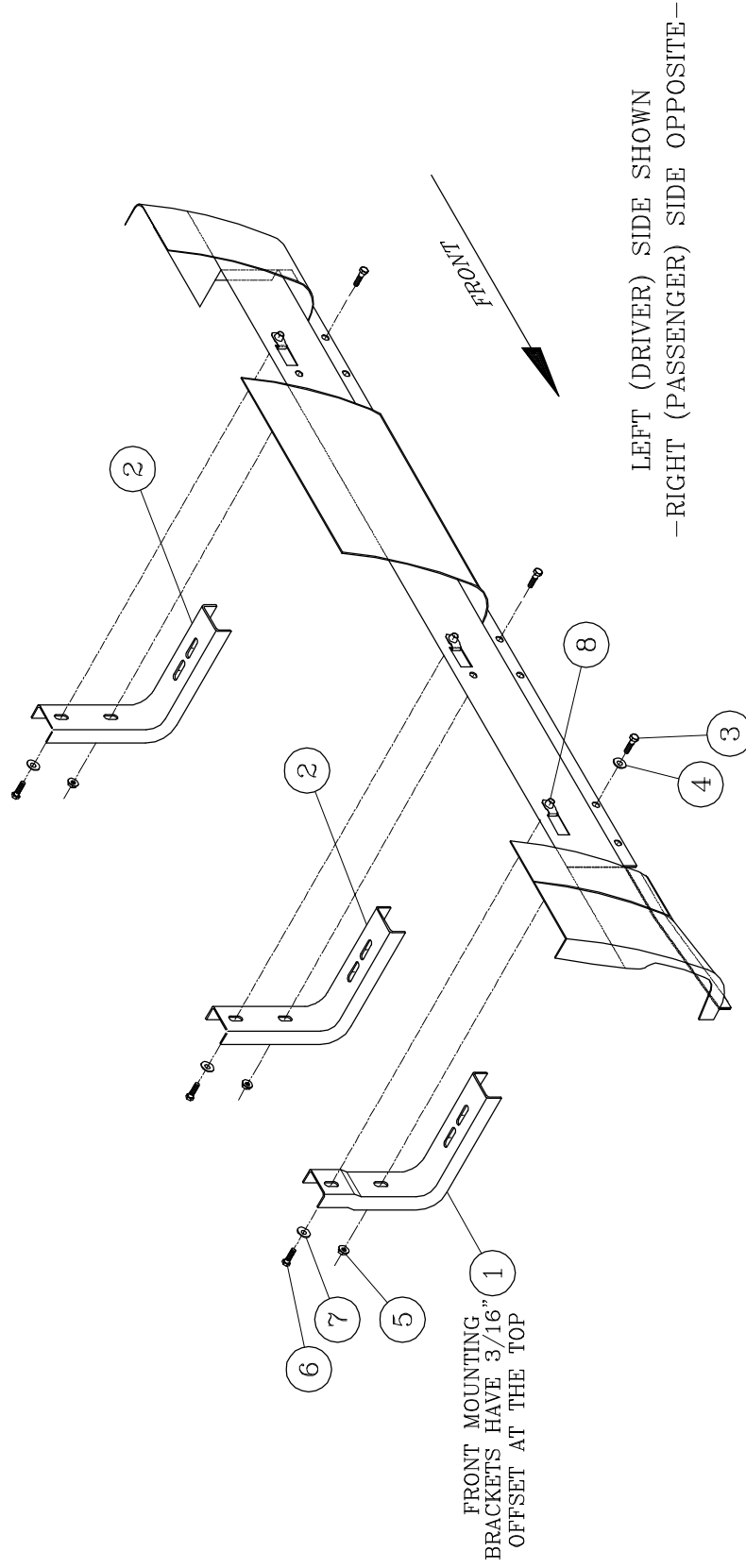

FIG. 1



1200 E. Brady St.
Arundel, SD 57005

REVISION B 05MAR12
REVISION A 11OCT11
551963 SHEET 2 28JUL11